

NCE
The Power of DCC

EB3

Circuit Breaker

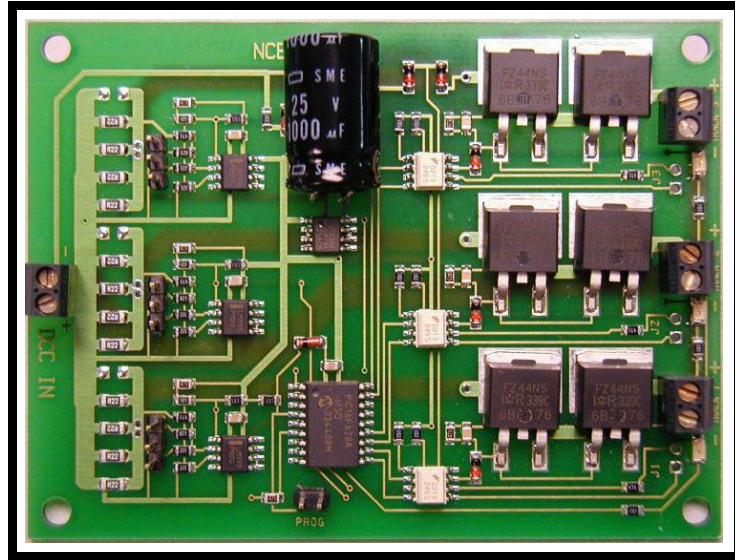

\$54.95

Three output electronic circuit breaker
for use on DCC layouts only.

Features of the EB3:

- ✓ Provides short circuit protection for up to three power districts
- ✓ Trip current of each power district adjustable for 2, 3 or 4 Amps
- ✓ Easy hookup using screw terminals , no soldering
- ✓ Status indication LEDs for each output
- ✓ Additional opto-isolated outputs provided to feed signal circuits or control panel indicators
- ✓ Adjustable short circuit response time
- ✓ Adjustable power-up response time to accommodate startup of sound decoder equipped loco motives



05240217

This book, schematics and artwork Copyright 2006
NCE Corporation Webster, NY 14580

Description:

It is usually desirable to divide a layout into separate track power sections (power districts). The EB3 can be used to divide the power output of one DCC booster into three independent power districts each with its own short circuit protection. Note: The EB3 is designed to be used only with DCC systems. It will not work with any power system other than DCC.

Mechanical Installation:

The EB3 has 4 mounting holes that can be used to mount it to a convenient place on your layout. We recommend using #4 x 3/4" round head wood screws with #4 flat washers. Do not over tighten the screws. Lightly snug the screws up just enough to keep the circuit board in place without bending it. Bending the circuit board can fracture the fragile ceramic electronic components.

Electrical Connections:

The diagram below illustrates the wiring of the EB3 to your layout. The terminal strips on the EB3 accept up to #14 AWG wire. For distances to 20 feet (6.5 meters) from the **booster to the EB3** you should use at least #16 AWG wire and #14 for runs out to 40 feet. Wiring from the EB3 to the track should be #16 up to about 30 feet, and larger if you need longer runs. We recommend track feeder wires every 10-12 feet when using code 83 or larger rail size. If you're using code 70 or smaller rail we suggest feeders every 6 feet. Insufficient feeders can cause enough voltage drop to prevent the circuit breaker from working.

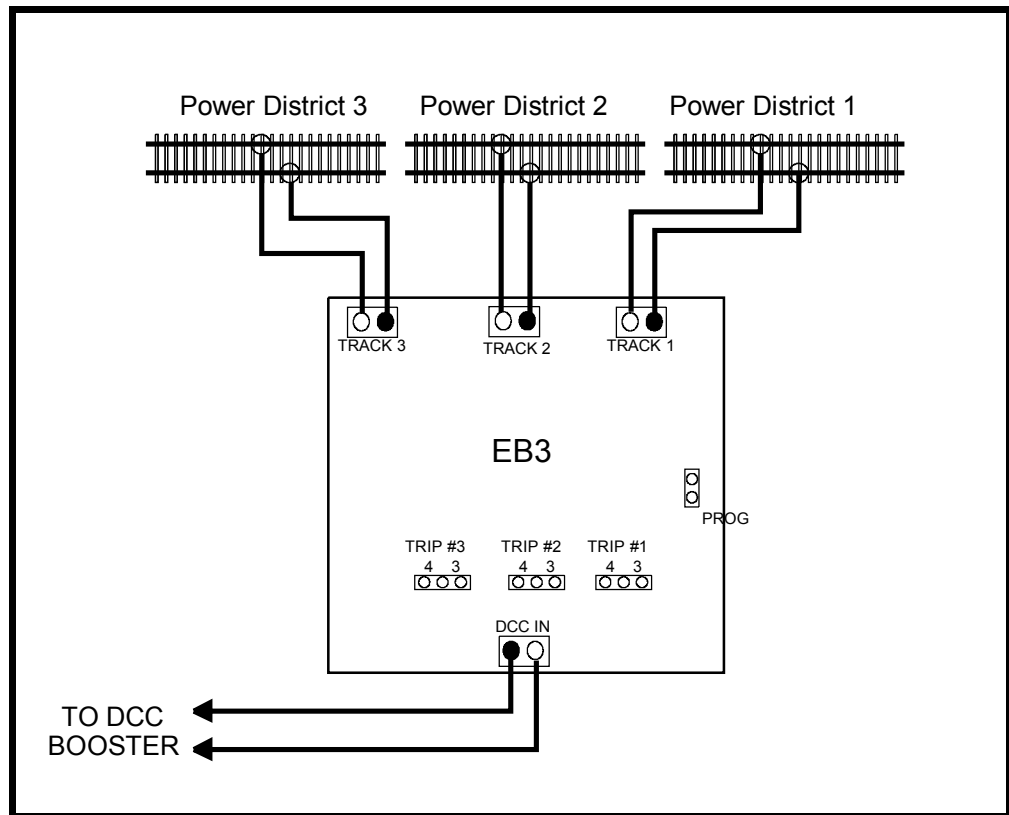

Note: The screw terminals marked with black dots in the drawing are connected together internally on the EB3 circuit board. If you are using common rail make sure the terminals marked in black above are connected to the common rail (bottom rail in the diagram).

At this point the EB3 is ready to use. The factory settings have been chosen to provide suitable operation with most HO and N scale layouts. If desired you can fine tune the operating parameters of the EB3 to more closely match your DCC system and layout using the information presented on the following pages. Before jumping in and changing any settings we suggest trying the EB3 with the original factory settings.

Setting trip current:

The EB3 comes from the factory with the trip current for each power district set to 2 Amps. You can set the trip current for each district higher by using circuit "shunts". Shunts are the small black plastic pieces supplied with the EB3. If no shunt is installed the trip current is 2.25 Amps. The diagram below illustrates the locations of shunts to set the trip current in a power district to 3 or 4 Amps. To install a shunt simply slip it over the indicated pins on the circuit board. The diagrams below depict enlarged regions of the EB3 circuit board. Use the larger diagram on Page 2 to locate the areas of the circuit board that correspond to each track power district

3 Amp Shunt

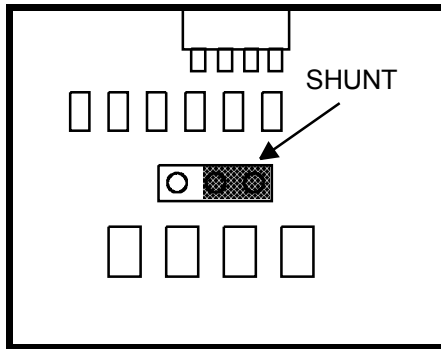

4 Amp Shunt

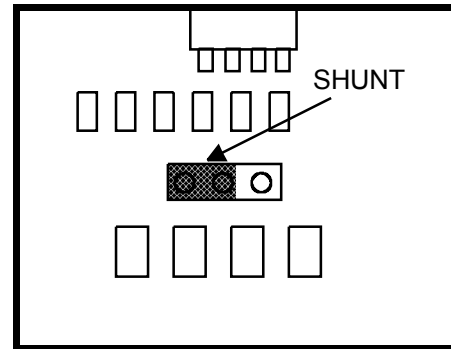

Testing the installation:

After setting the trip current we recommend testing your wiring. The "quarter test" is the fastest way to test your wiring. Use a coin or other piece of metal to short across the rails at various places in a power district. The corresponding circuit breaker in the EB3 should trip and shut down the power district at every place you short out the track. Once shut down the EB3 will try to restore power about 1 a second to the track. If there is still a short the EB3 will kill the power again, until the short is removed.

Status Indicators:

There is a status indicator LED located next to the "TRACK" connector for each power district. Each LED will light steadily if everything is OK. A flashing LED indicates the corresponding breaker for that power district has tripped. All three LEDs off usually indicates the DCC power booster is turned off.

Adjustment of short circuit response time (if necessary):

You can adjust the time delay between the occurrence of a short circuit and the time the track actually gets shut off by the breaker. The EB3 comes factory set to 100mS (1/10 second). This setting has been chosen because it can be used without problem on most layouts. If your booster shuts down before the EB3 you can shorten this delay.

Any DCC system that has OPS mode programming (Program On the Main) for locomotives can adjust the response time. The EB3 will respond to OPS mode programming no matter what locomotive address is used. We recommend choosing an address that is not used on your layout (we use 9999).

To set the response time for track power district 1:

- Install a shunt on the two pins marked "PROG" on the EB3
- Use OPS mode programming to program CV49 to the number of milliseconds (divided by 10) you desire between 10mS and 500mS. A value of 1 = 10mS, a value of 20 = 200mS, etc.

•Remove the shunt when done programming.

CV49 sets the response time for Track 1
CV50 sets the response time for Track 2
CV51 sets the response time for Track 3.

Valid values for CV49 to CV51 range from 0 (no delay) to 63 (630 mS). Numbers larger than 63 will cause the default of 10 (100mS) to be used.

