

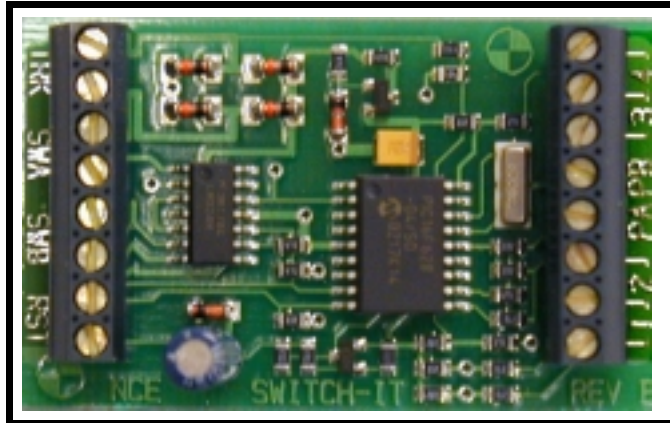

# Switch-It

Accessory Decoder



FOR STALL

MOTOR MACHINES ONLY

NOT FOR USE WITH TWIN COIL SWITCH MACHINES

Dimensions: 2.1" x 1.3" (54 x 33 mm)

Decoder revision B-1

**\$24.95**

## **Now with EASIER PROGRAMMING!**

**This is an accessory (switch machine) decoder**

- , Control for two Tortoise™ switch machines
- , Switch-It remembers the position of switch during power outages
- , Switch-It supports the full range of DCC accessory addresses (1-2044)
- , Easy address programming, no need to connect it to programming track
- , Each switch machine can have its own completely different address
- , Simple hook up, 2 wires to the track, 2 wires to each switch machine
- , Includes optional connections for "local" control push buttons
- , Also operates on non-DCC layouts

**Every attempt has been made to ensure this decoder complies with all applicable  
NMRA Standards and Recommended Practices**

This book, schematics and artwork copyright 2000-2003  
NCE Corporation 899 Ridge Road Webster, NY 14580

Switch-It is a trademark of NCE Corporation

## Installation Notes:

This decoder is designed to control Tortoise, SwitchMaster or other low current "stall motor" switch machines. The outputs are rated for 50mA maximum. Most Tortoise machines draw 20 to 25mA with normal track voltage (about 13-15 volts). We use double sided foam tape to mount the Switch-It to the side of a Tortoise.

## Wiring:

See the diagram below for wiring particulars. The only required wires are two wires to the track and two wires to each machine. It is OK to use the Switch-It for control of only one machine.

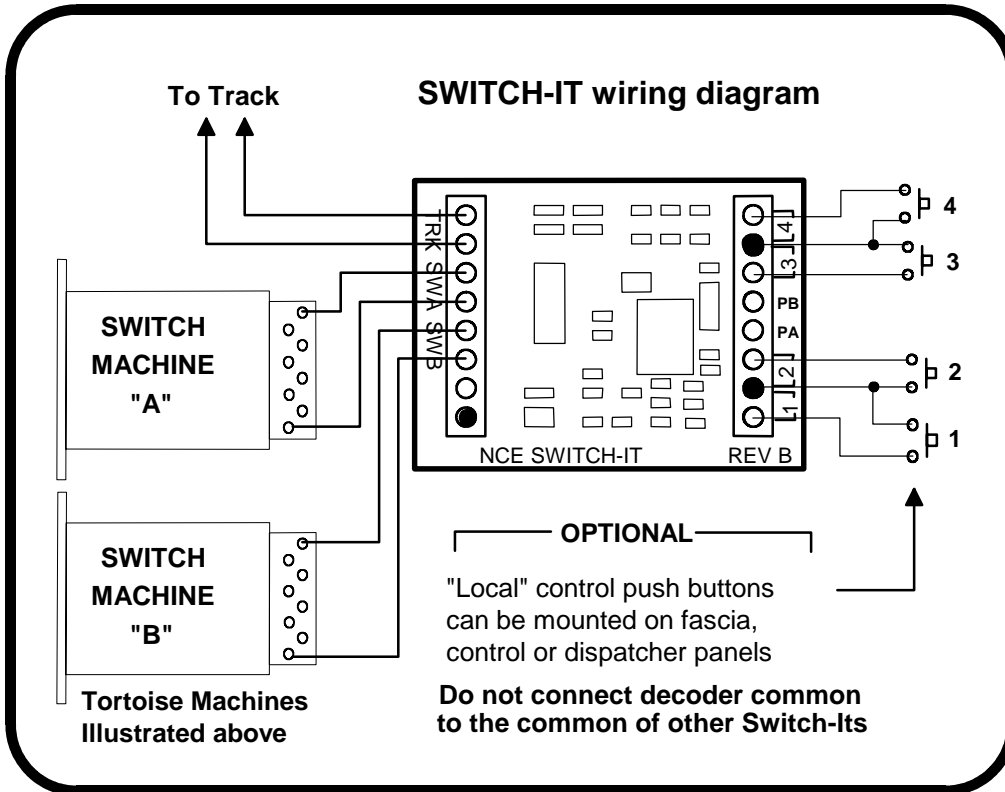

## Optional push buttons:

Push buttons may be added for local control of the switches. Buttons 1 and 2 control switch "A" and buttons 3 and 4 control switch "B". Use momentary contact switches for local control. **Do not use a toggle switch** (unless it is momentary), its continuous connection will prevent DCC control of the turnout. In the illustration above the push button terminals filled in with black are "common" with each other. Buttons 1 and 2 are shown wired with a common wire to each push button as are buttons 3 and 4. It is OK to use only one common wire for all 4 push buttons. You can have multiple buttons wired in parallel for operation of the machine from more than one control panel. If the Switch-It is used on DC (12-16 volts DC) the buttons will still work. You can also program the Switch\_It to "toggle" the outputs with each push of the local control pushbuttons. Button 1 will control the SWA output and button 4 will control the SWB output. Buttons 2 and 3 will be ignored and are not needed.

## Switch machine mounting tip:

On our Tortoise machines we use hot glue to mount the machine. The glue stays liquid just long enough after application to allow alignment of the machine. We manually center the arm of the machine then slide the machine around while the glue sets to align the points to the middle of their throw. The low temperature hot glue is weak enough to allow removal of the machine later on by prying with a putty knife. Use a throw wire that is about 6" (150mm) longer than the one provided with the Tortoise to give you room to put glue on the machine after the wire is put through the roadbed.

### Factory default values for decoder

Output SWA is factory programmed to accessory address 1 (decoder addr 1, output 1)  
Output SWB is factory programmed to accessory address 2 (decoder addr 1, output 2)  
CV547 is set to 0 (Power up exercising of switch machine disabled)  
CV548 is set to 0 (use pushbutton 1 to "toggle" output SWA, pushbutton 2 is disabled)  
CV549 is set to 0 (use pushbutton 4 to "toggle" output SWB, pushbutton 3 is disabled)

### Programming information

The Switch-It **cannot** be programmed on your programming track. It is always programmed while connected to the mainline track. This decoder can be programmed by all systems that support accessory control using the procedure below.

#### To program switch "A" to a new address using any DCC system:

- 1) Connect wires from the track to the decoder **TRK** connections.
- 2) Connect a short "jumper" wire from the **PA** terminal to common as shown below.
- 3) Use your DCC system to control the accessory (switch) number you wish the decoder to use as its address for the **SWA** output.
- 4) Remove the jumper wire.

#### To program switch "B" to a new address using any DCC system:

- 1) Connect wires from the track to the decoder **TRK** connections.
- 2) Connect a short "jumper" wire from the **PB** terminal to common as shown below.
- 3) Use your DCC system to control the accessory (switch) number you wish the decoder to use as its address for the **SWB** output.
- 4) Remove the jumper wire.

Do **not** leave the jumper in place after programming or you will not be able to control the switch.

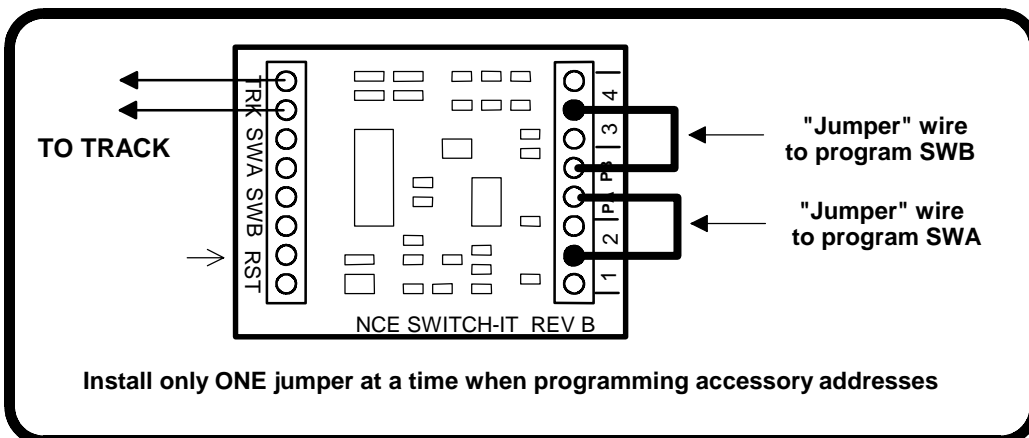

#### To set the decoder to "exercise" the switch points at each power up:

Momentarily connect both **PA** and **PB** to **common**. Don't issue any accessory commands while these jumpers are connected or you will also program the decoder address.

You can also use the PROG ACCESSORIES feature of your NCE Powerhouse Pro. Set CV547 = 1 (use the accessory address of SWA) to enable the 'exercise' option or set CV547 = 0 to disable it.

#### To set pushbutton 1 to "toggle" the SWA output (disables pushbutton 2):

- 1) Disconnect track power to the Switch-It.
- 2) Connect **PA** to the left **RST** terminal indicated by the arrow in the above figure.
- 3) Re-connect track power to the Switch-It
- 4) Remove the **PA** to **RST** jumper

You can also use the PROG ACCESSORIES feature of your NCE Powerhouse Pro. Set CV548 = 1 (use the accessory address of SWA) to enable the 'toggle' option or set CV548 = 0 to disable it.

#### To set pushbutton 4 to "toggle" the SWB output (disables pushbutton 3):

- 1) Disconnect track power to the Switch-It.
- 2) Connect **PB** to the left **RST** terminal indicated by the arrow in the above figure.
- 3) Re-connect track power to the Switch-It
- 4) Remove the **PB** to **RST** jumper

You can also use the PROG ACCESSORIES feature of your NCE Powerhouse Pro. Set CV548 = 1 (use the accessory address of SWA) to enable the 'toggle' option or set CV548 = 0 to disable it.

**Factory reset:**

Momentarily connecting the RST terminals will reset the decoder to the factory default accessory address of 1 for SWA and 2 for SWB. This will also disable the "exercise" feature.

**Other technical stuff:**

- √ We have successfully controlled two Tortoise switch machines with one decoder output when used in a crossover. We can't guarantee this will work in all cases.
- √ The outputs of the decoder are always on to prevent the switch machine from backing off due to the springiness of the turnout throw mechanism.
- √ If CV547 is programmed to 1 ("exercise" enabled) the decoder will "back off" the switch (usually about halfway) then return the switch to its remembered position at power up. This is to make sure the points are fully thrown (solves sticky point problems).
- √ See the diagram below for turnout position indicator light wiring. LEDs are wired in series with the switch machine to indicate which position the turnout is thrown. Most LEDs will handle up to 25mA, the switch motor acts as the current limiting device for the LEDs. We use red and green LEDs but any color will do. The switch machine will run a bit slower with LEDs installed due to about a 1.5 volt loss in the LED.

**TIP:**

If you use power routing turnouts such as Peco Electro-Frog, Shinohara or Walthers we suggest wiring a #1156 automotive taillight bulb in series with the points of the turnout (see above). This will prevent short circuits from shutting down your power booster in the event you enter the turnout from the frog end without aligning the points.

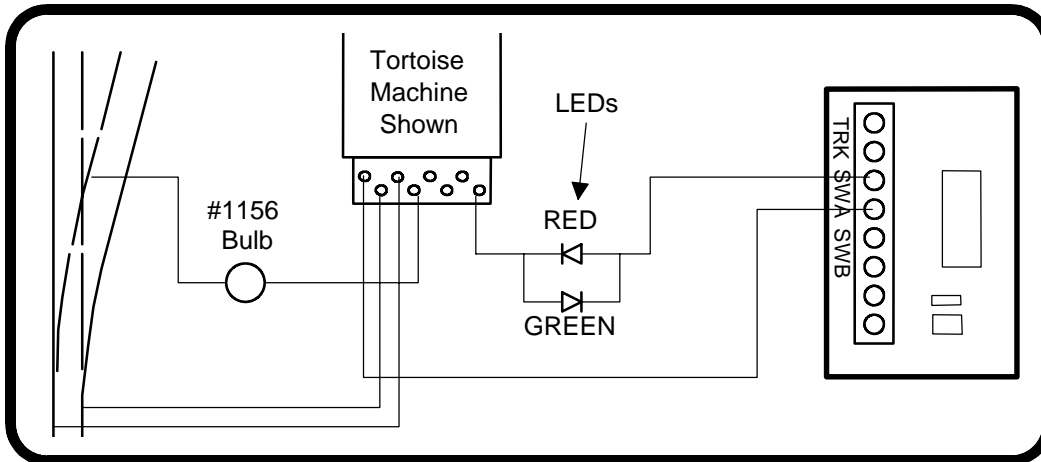

The warranty is voided if the decoder is miswired, connected to more than 22 volts, or used with switch motors drawing more than 40mA.

**Warranty**

This decoder is fully factory tested and warranted against manufacturing defects for a period of 1 year. As the circumstances under which this decoder is installed can not be controlled, failure of the decoder due to installation problems can not be warranted. This includes misuse, miswiring, operation under loads beyond the design range of the decoder or short circuits in the locomotive manufacturer's factory wiring. If the decoder fails for non-warranted reasons NCE will replace the decoder, no questions asked, for \$10 U.S. plus \$2 shipping. For warranty or non-warranty replacement send the decoder (an any payment, if required) to:

**NCE Warranty Center**

**899 Ridge Road**

**Webster, New York 14580**

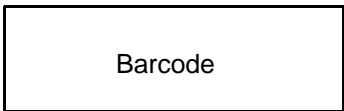

The terms Silent Running, Powerhouse Pro, Power Pro, Powerhouse Digital Command Control, ProCab, Switch-It, Snap-It, the NCE logo with "Power of DCC" slogan and EFX are trademarks of NCE Corporation. Digitrax is a trademark of Digitrax Inc.