

# NICE

*The Power of DCC*

## Switch-8

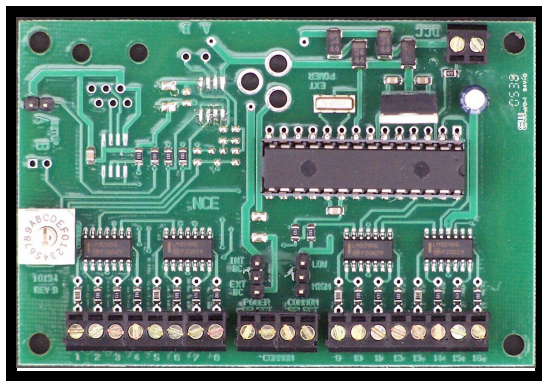

FOR STALL MOTOR MACHINES ONLY

NOT FOR USE WITH TWIN COIL SWITCH MACHINES

**\$59.95**

**EASY PROGRAMMING!**

- ✓ Control for 8 Tortoise™ switch machines
- ✓ Remembers the position of switch during power outages
- ✓ Supports the full range of DCC accessory addresses (1-2044)
- ✓ Easy address programming, no need to connect it to programming track
- ✓ Each switch machine can have its own completely different address
- ✓ Simple hook up, 2 wires to the track, 2 wires to each switch machine



05240136

**Warning:** This product contains chemicals known to the state of California to cause cancer, birth defects or other reproductive harm.

**Notes:**

This decoder is designed to control Tortoise, SwitchMaster or other low current "stall motor" switch machines. The outputs are rated for 50mA maximum. Most Tortoise machines draw 10 to 20mA with normal track voltage (about 13-15 volts). There are four mounting holes at the corners of the Switch-8.

**Wiring:**

See the diagram below for wiring particulars. The only required wires are two wires to the track and two wires to each machine. It is OK to use the Switch-8 for control of less than 8 machines.

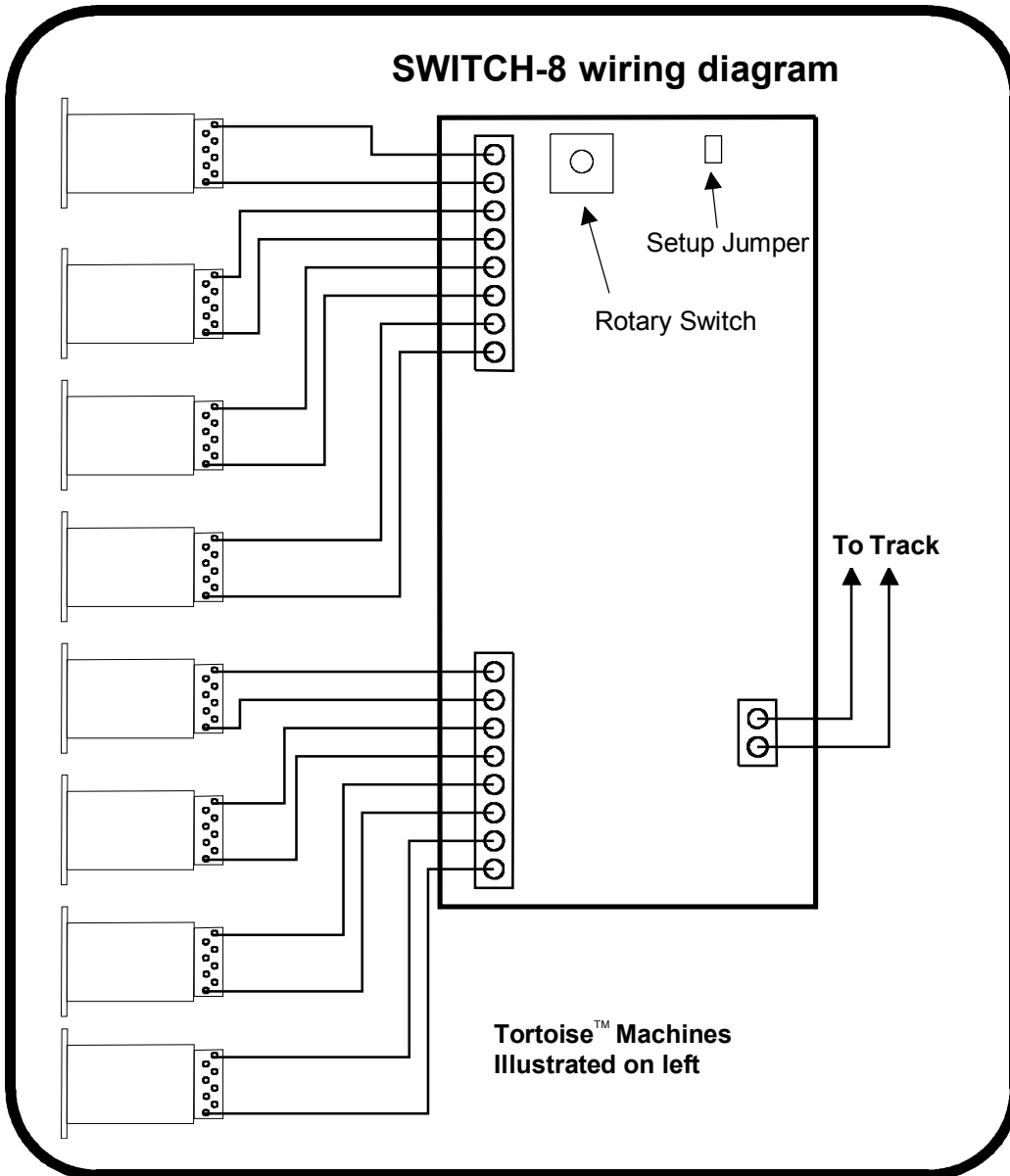

**Switch machine mounting tip:**

On our Tortoise machines we use hot glue to mount the machine. The glue stays liquid just long enough after application to allow alignment of the machine. We manually center the arm of the machine then slide the machine around while the glue sets to align the points to the middle of their throw. The low temperature hot glue is weak enough to allow removal of the machine later on by prying with a putty knife. Use a throw wire that is about 6" (150mm) longer than the one provided with the Tortoise to give you room to put glue on the machine after the wire is put through the roadbed.

**Factory default values for decoder**

Outputs 1&2 factory programmed to accessory address 1  
Outputs 3&4 factory programmed to accessory address 2  
Outputs 5&6 factory programmed to accessory address 3  
Outputs 7&8 factory programmed to accessory address 4  
Outputs 9&10 factory programmed to accessory address 5  
Outputs 11&12 factory programmed to accessory address 6  
Outputs 13&14 factory programmed to accessory address 7  
Outputs 15&16 factory programmed to accessory address 8

**Programming information**

The Switch-8 **can not** be programmed on your programming track. It is always programmed while connected to the mainline track. This decoder can be programmed by all systems that support accessory control using the procedure below.

**To program output 1&2 to a new address using any DCC system:**

- 1) Connect wires from the track to the decoder **TRK** connections.
- 2) Turn the rotary switch on the Switch-8 to the "0" position
- 3) Install the programming jumper plug on the SETUP A pins.
- 4) Decide what you want the new switch address to be, then use your DCC controller to throw that switch (see below).
- 5) The decoder will accept that switch address for its new address and exit programing mode.
- 6) Remove the setup jumper plug.

Do **not** leave the setup jumper in place after programming or you will not be able to control the switch.

**To program outputs 3-16 to a new address using any DCC system:**

Turn the rotary switch to the indicated number and follow the above instructions for programming.

Outputs	Rotary switch setting
1 and 2	0
3 and 4	1
5 and 6	2
7 and 8	3
9 and 10	4
11 and 12	5
13 and 14	6
15 and 16	7

**To throw a switch using the NCE system:**

Press "SEL ACCY"

Type in the accessory number followed by "ENTER"

Push "1" to throw the switch.

**To throw a switch using a Digitrax system:**

Press "SWCH"

Type in the accessory number

Push "OPTN" to throw the switch.

**To throw a switch using a Lenz system:**

Press "F"

Press "5"

Type in the accessory number followed by "ENTER"

Push "+"

**Reversing the polarity of an output:**

Use OPs mode programming for accessories (“PROG” followed by “7” on NCE systems) to program CV33 to a value of 1.

If your DCC system does not support OPs mode programming for accessories you can just swap the two wires to the switch machine.

NOTE:The commands for Accessory OPS mode programming have been changed. By the NMRA Only NCE system versions later than October 20, 2006 (Power Cab version 1.28) issue the new type programming command. There are no other known DCC systems that support OPs mode programming for Accessory or Signal decoders at this time.

**Other technical stuff:**

- We have successfully controlled two Tortoise switch machines with one decoder output when used in a crossover. We can't guarantee this will work in all cases.
- The outputs of the decoder are always on to prevent the switch machine from backing off due to the spring of the turnout throw mechanism.
- See the diagram below for turnout position indicator light wiring. LEDs are wired in series with the switch machine to indicate which position the turnout is thrown. Most LEDs will handle up to 25mA, the switch motor acts as the current limiting device for the LEDs. We use red and green LEDs but any color will do. The switch machine will run a bit slower with LEDs installed due to about a 1.5 volt loss in the LED.

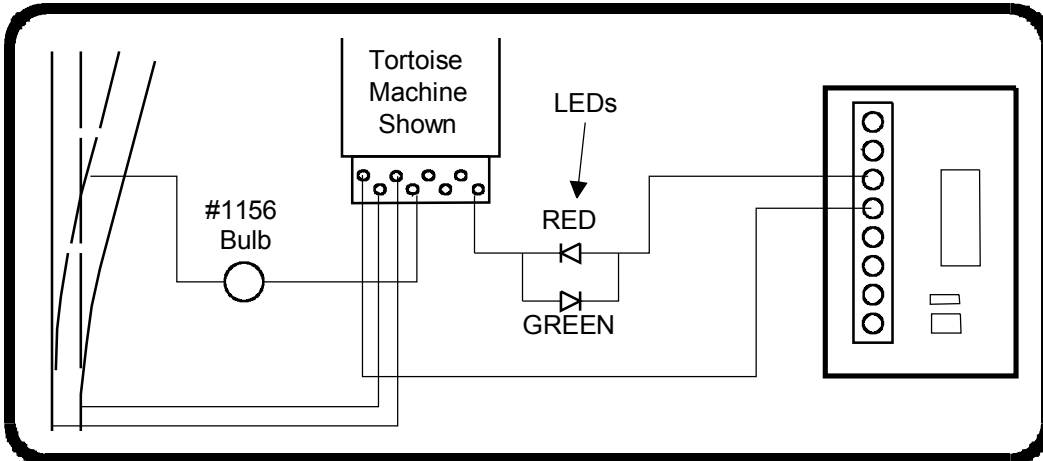

**TIP:**

If you use power routing turnouts such as Peco Electro-Frog, Shinohara or Walthers we suggest wiring a #1156 automotive taillight bulb in series with the points of the turnout (see above). This will prevent short circuits from shutting down your power booster in the event you enter the turnout from the frog end without aligning the points.

The warranty is voided if the decoder is miswired, connected to more than 22 volts, or used with switch motors drawing more than 40mA.

**Warranty**

This decoder is fully factory tested and warranted against manufacturing defects for a period of 1 year. As the circumstances under which this decoder is installed can not be controlled, failure of the decoder due to installation problems can not be warranted. This includes misuse, miswiring, operation under loads beyond the design range of the decoder or short circuits. If the decoder fails for non-warranted reasons NCE will replace the decoder, no questions asked, for \$0 US plus \$2 shipping. For warranty or non-warranty replacement send the decoder (an any payment, if required) to:

**NCE Warranty Center**  
82 Main Street  
Webster, New York 14580



05240136

The terms Silent Running, Powerhouse Pro, Power Pro, ProCab, Power Cab, the NCE logo with “Power of DCC” slogan and the distinctive shape of the ProCab with thumbwheel and LCD are trademarks of NCE Corporation. Digitrax is a trademark of Digitrax Inc.